



MEB3LE-63 1P+N



MEB3LE-63 2P



MEB3LE-63 3P



MEB3LE-63 3P+N



MEB3LE-63 4P

Application

MEB3LE-63 series earth leakage circuit breakers (hereinafter referred to as earth leakage circuit breakers) are suitable for use in circuits with rated voltage 230 or 400V, frequency 50/60Hz, rated current up to 63A and below, as protection against personal electric shock, as well as protection against leakage, overload and short-circuit of electrical circuits and equipment in houses and similar buildings, and for infrequent operation and conversion of circuits.

The product complies with GB/T16917.1, GB/T16917.22 and IEC61009-1 standards.

Normal working and installation conditions

2.1 Normal operating conditions

2.1.1 Ambient air temperature -5 °C to 40 °C, not exceeding 35 °C on average within 24 h.

2.1.2 The altitude of the installation site does not exceed 2000 m.

2.1.3 The relative humidity of the air at the installation site shall not exceed 50% at a maximum temperature of 40 °C and 90 % at a monthly average minimum temperature of 25°C in the wettest month.

2.1.4 Pollution level 2 at the installation site.

2.2 Installation category: Installation category III.

2.3 The installation shall be free from significant shocks and vibrations.

2.4 The installation position should be vertical, with an inclination of no more than ±5° in all directions.

Structure and working principle

The earth leakage circuit breaker consists of an ADB3 mini circuit breaker and an earth leakage release assembled together.

When there is leakage or personal electric shock in the protected circuit, the vector sum of the current through the zero sequence current transformer is not equal to zero, the secondary coil of the transformer generates a voltage signal and is amplified by the integrated circuit. When the rectification value is reached, the leakage release actuates, so that the circuit breaker cuts off the power within 0.1 seconds, thus playing the role of electric shock and leakage protection.

When an overload and short circuit occurs in the line or equipment, the overload release or instantaneous release in the circuit breaker acts to cut off the power supply and protect the line and equipment from damage.

Types and meanings, technical parameters

ME B 3 LE - □ / □ □ □ □
 1 2 3 4 5 6 7 8 9

1. Company code

2. Circuit breaker

3. Design serial number

4. Earth leakage circuit breaker

5. Frame class rated current (A)

6. L is for integrated modules, not marked as discrete components

7. Number of poles

8. When with a non-disconnectable neutral, denoted by N

9. Instantaneous release type B, C or D

Main technical parameters (see Table 1)

Table 1

| Frame class rated current Inm (A) | Number of poles | With neutral wire | Rated current In (A) | Rated short circuit capacity | | | Overcurrent instantaneous release type | Rated earth leakage trip current IΔn(mA) | Rated earth leakage non-trip current (mA) | Rated earth leakage breaking time (s) | Rated impulse withstand voltage(kV) |
|-----------------------------------|-----------------|-------------------|---|------------------------------|--------------------------|------|--|--|---|---------------------------------------|-------------------------------------|
| | | | | Voltage (V) | Breaking capacity Icn(A) | Cosφ | | | | | |
| 32 | 1 | N | 6, 10 16, 20 25, 32 | 230 | 6000 | 0.8 | B C D | 30 50 | 15 25 | ≤0.1 | 4 |
| | 2 | | | | | | | | | | |
| | 3 | | | | | | | | | | |
| | 3 | N | | | | | | | | | |
| 63 | 1 | | 6, 10 16, 20 25, 32 40, 50 63 | 230 | 6000 | 0.8 | B C D | 30 50 | 15 25 | ≤0.1 | 4 |
| | 2 | | | | | | | | | | |
| | 3 | | | | | | | | | | |
| | 3 | N | | | | | | | | | |
| | 4 | | | 400 | | | | | | | |

4.2.2 Overcurrent tripping characteristics (see Table 2)

Table 2

| No. | Overcurrent instantaneous release type | Rated current In A | Initial state | Test current A | Rated time t | Expected results | Remark |
|-----|--|--------------------|---------------|----------------|--------------|------------------|--|
| a | B、C、D | ≤63 | Cold state | 1.13In | t≤1h | Non-trip | - |
| b | B、C、D | ≤63 | Hot state | 1.45In | t<1h | Trip | Ramp up to the specified current within 5s immediately after the test in item a) |
| c | B、C、D | ≤32 | Cold state | 2.55In | 1s<t<60s | Trip | - |
| | | >32 | Cold state | | 1s<t<120s | | |
| d | B | ≤63 | Cold state | 3In | t≤0.1s | Non-trip | Close the auxiliary switch and turn on the power |
| | C | | Cold state | 5In | | | |
| | D | | Cold state | 10In | | | |
| e | B | ≤63 | Cold state | 5In | t<0.1s | Trip | |
| | C | | Cold state | 10In | | | |
| | D | | Cold state | 20In | | | |

4.2.3 Rated residual breaking capacity (I^Δm) 2000A, mechanical and electrical life: 15000 cycles (on - off).

4.2.4 The circuit breaker with overvoltage protection has an action range of 280V ± 5 %.

■ Outline and installation dimensions

5. 1 Outline and installation dimensions (see table 3、figure 1)

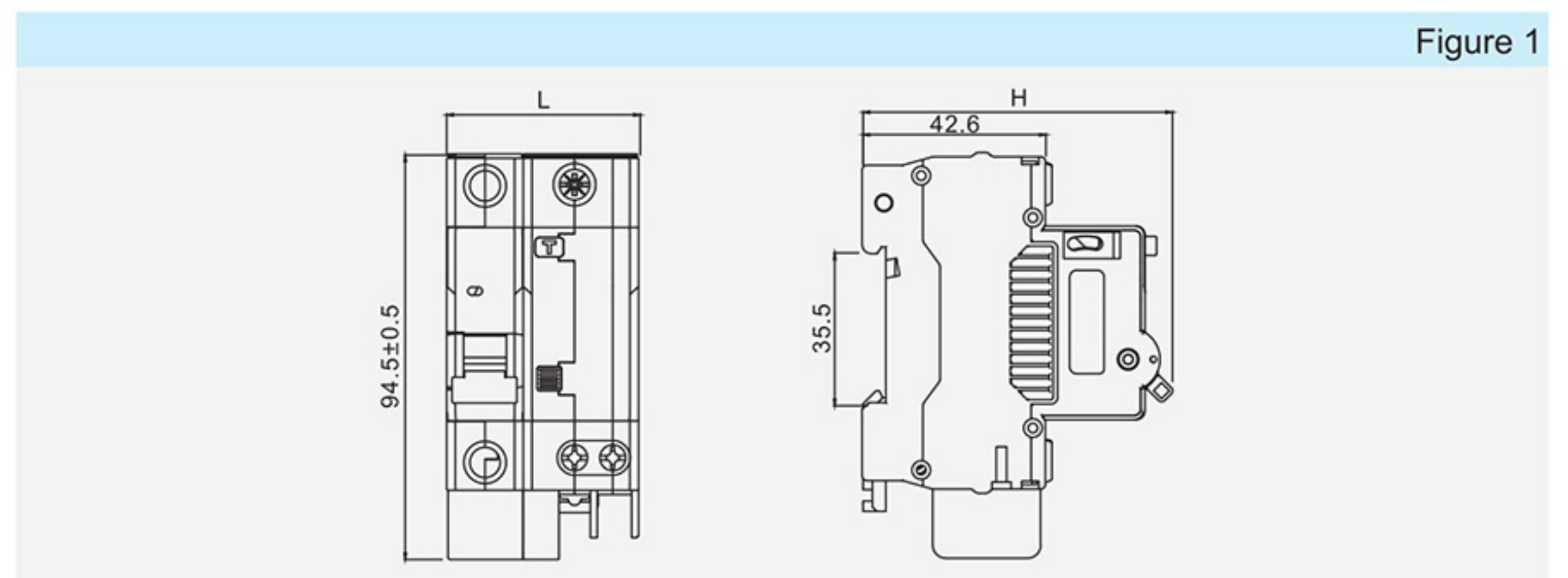

Table 3

| No.of poles | 1P+N | 2P | 3P | 3P+N | 4P | Remark |
|-------------|---------|-----------|-----------|-----------|-----------|-----------|
| L mm | 54±0.50 | 72±0.50 | 104±0.50 | 117±0.50 | 135±0.50 | MEB3LE-63 |
| L mm | 45±0.50 | 63±0.50 | 90±0.50 | 99±0.50 | 117±0.50 | MEB3LE-32 |
| H mm | 72±0.50 | 74.5±0.50 | 74.5±0.50 | 74.5±0.50 | 74.5±0.50 | |

■ Use and maintenance

6.1 The overcurrent release characteristics and leakage characteristics of the earth leakage circuit breaker are rectified by the manufacturer. users should not adjust them at will during installation and use to avoid affecting the performance.

6.2 The incoming power supply line must be connected directly above the earth leakage circuit breaker and the outgoing line should be connected below, not upside down, otherwise it will cause damage to the product.

6.3 When the earth leakage circuit breaker is installed, the handle in the "OFF" position means "break" and in the "ON" position means "close", the circuit is switched on.

6.4 After a new installation or after a certain period of operation (generally every month), the circuit breaker should be switched on and off and the test button should be pressed to check whether the leakage protection performance is normal and reliable.

6.5 In the event of a fault in the circuit breaker, if the leakage indicator button is protruding, it will indicate a leakage fault,press the earth leakage indicator button once the fault has been removed. If the leakage indicator button is not protruding, it indicates an overload or short-circuit fault, which must be removed before the switch can be closed.